

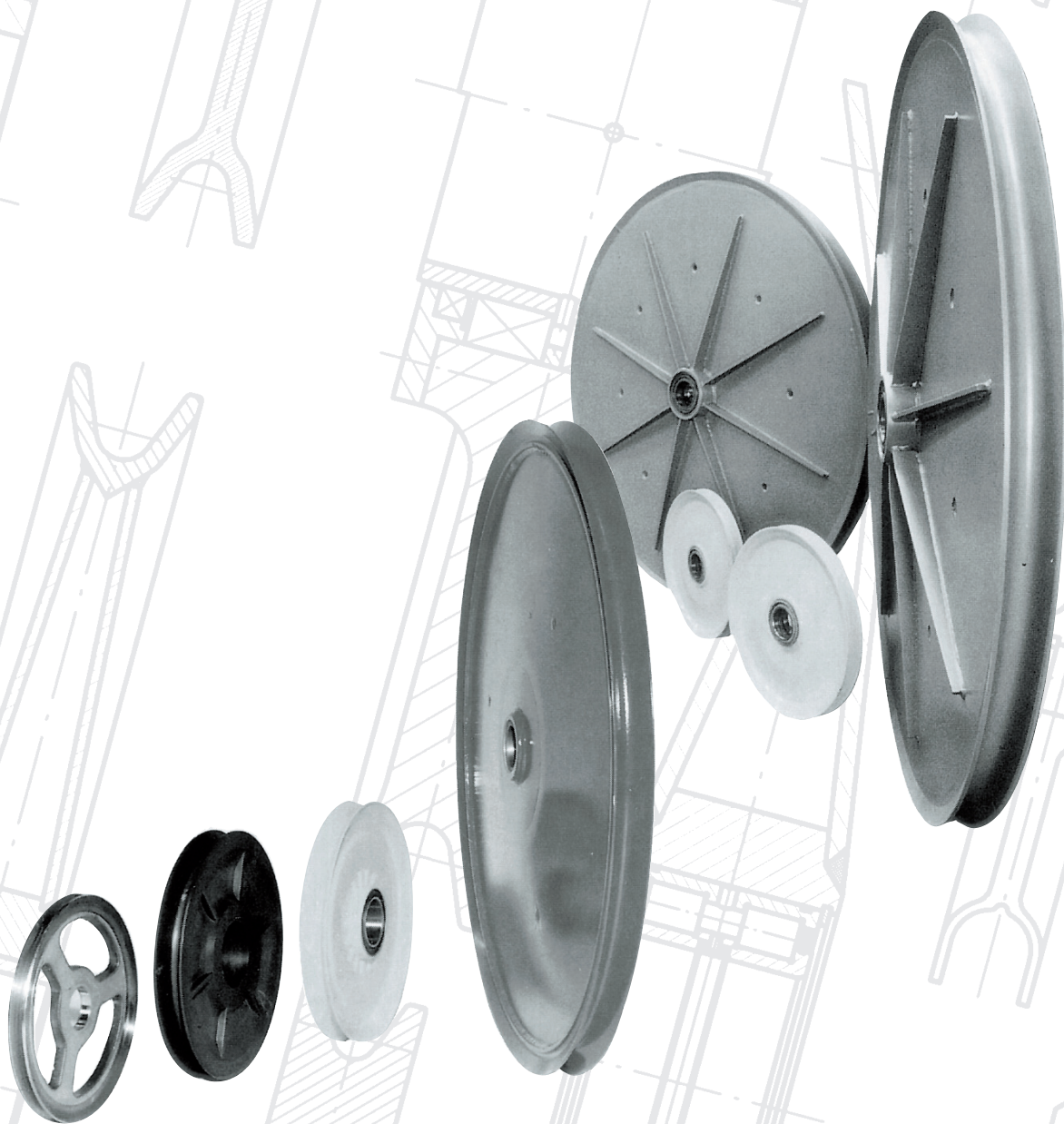

 **KoRo · IBS**  
MOVING AND BRAKE SYSTEM



## **Sheaves**

**According to DIN or customized**

Industrial Brakes · Thrusters · Pressure Oil Pumps · Couplings · Hydraulic Buffers · Cellular Buffers  
Rail Pliers · Sheaves · Hook Blocks · Crane Rail Wheels · Rail Clamps · Reparation · Service

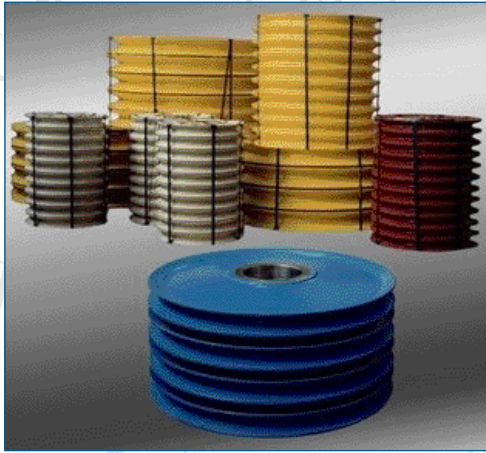

➤ **Principles for the production**

DIN, other standards, special design, customers' request

➤ **Production of the sheave**

Machined, welded, laminated, cast

➤ **Designs**

Spoke, core, double core type

➤ **Bearing of the sheave**

Slide bearing, friction bearing, roller bearing, without bearing (e.g. bore with fitting groove)

➤ **Groove profile**

According to DIN 15061, throat sheaves, special grooves, (e.g. double groove)

➤ **Special design**

e.g. sheaves for furnace, heat resistant more than 200° C

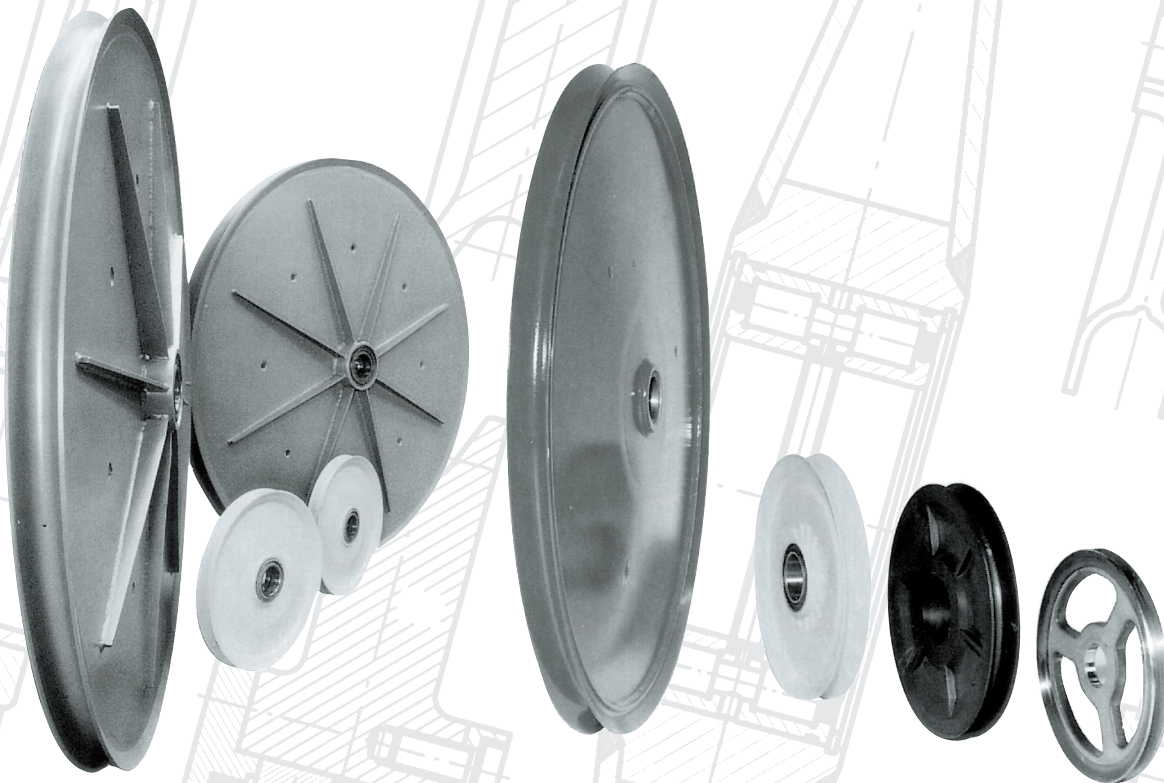

## General

Welded sheaves have proved their performance in both domestic and foreign markets. They are used as elements in machines for construction, extraction, in mines and for transportation.

## Description

Our experience in the production of welded sheaves also allows us to offer you a wide range of products for the domestic and foreign markets. We can also offer you different types so that all technical requirements of a project or a certain product can be met.

The design solutions are presented in the following:

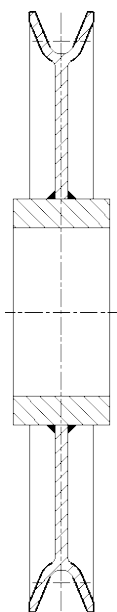

**Type A (1-web flange design)**

Sheaves made of plating open down the centre with the groove formed by cold forming. Due to their design and construction, they are normally used for small diameters.

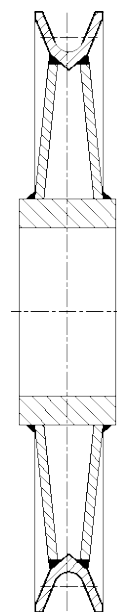

**Type B (2-web flange design)**

Sheaves with spokes, one of two spokes has an inclination of 30%, with variable sections. Depending on the diameter, end draw or the machine group, for which the sheaves are meant to be used, the spokes have a customised cross section.

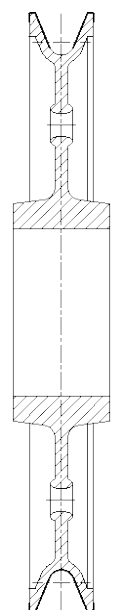

**Type C (casted)**

Sheaves with convex pulleys which make a more even stress distribution on the hub possible. So that model C is of great practical use for very high starting torques.

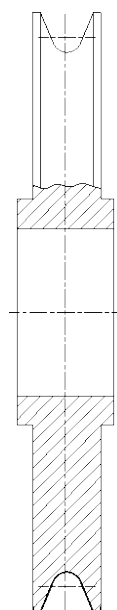

**Type D (forged plate)**

Sheaves made with a light central core and lateral stiffeners, mounted in a radial pattern. Model D is used for heavy load responsibility machines.

## Universal geometry <sup>1)</sup>

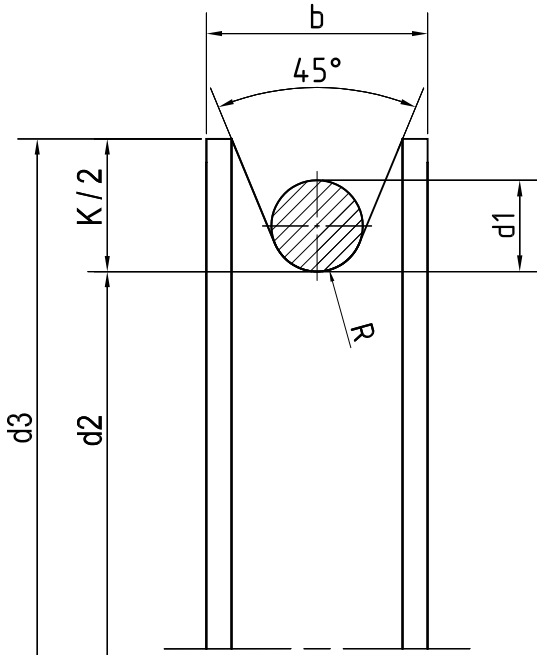

rope d1		R	K	b
from	to			
10	11	5,6	35	32
12	13	7	40	39
14	15	8	50	43
16	17	9	60	50
18	19	10	65	55
20	21	11	70	60
22	23	12	70	60
24	25	13	75	65
26	27	14	80	70
28	29	15	80	70
30	31	16	90	75
32	33	17	90	75
34	35	18	100	85
36	37	19	100	85

major rope diameter on request

$$d3=d2+K$$

## Variations of bearings

- A** double row cylindrical roller bearing, sealed on both side (lifetime lubricated)
- B** roller bearing, sealed on both side
- C** sliding bearings
- D** roller bearing, spacer and lateral cover in acc. w. DIN 15418
- E** roller bearing with internal bushes, with safety catch against rotation in acc. w. DIN 15421
- F** cylindrical roller bearing with internal bushes, with safety catch against rotation in acc. w. DIN 15422

1) variations on request

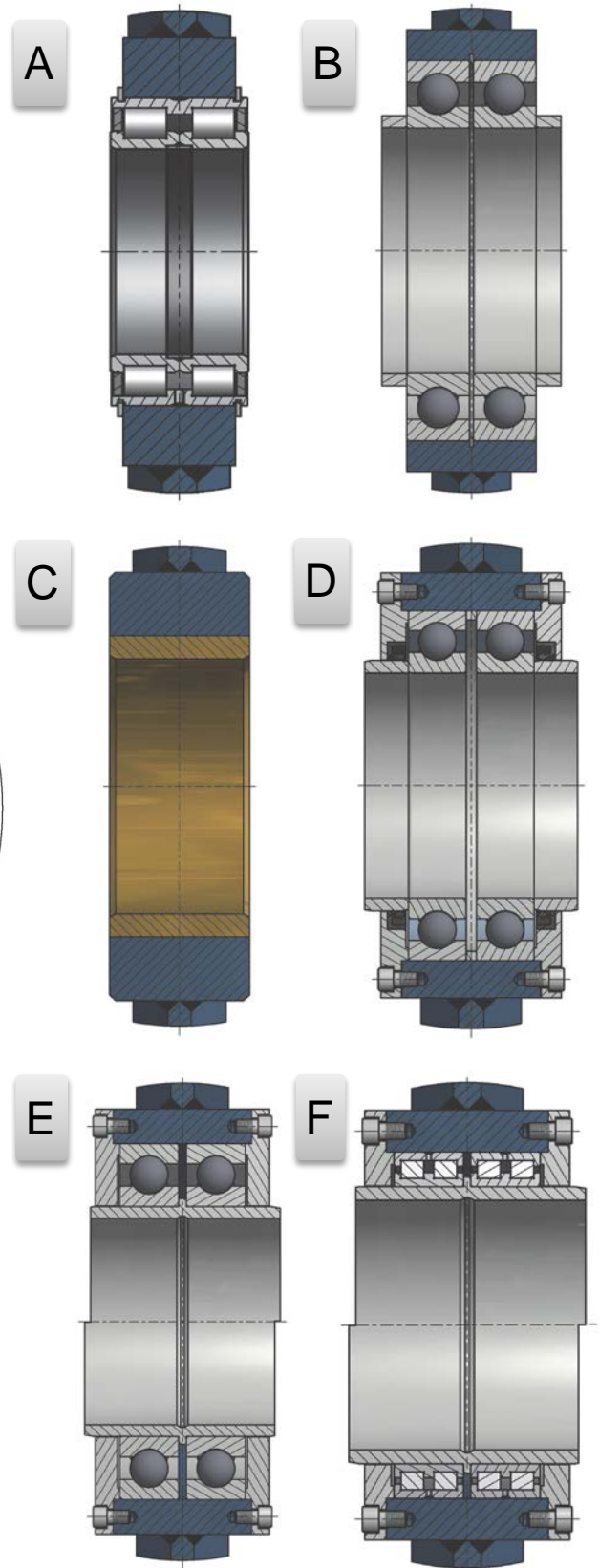
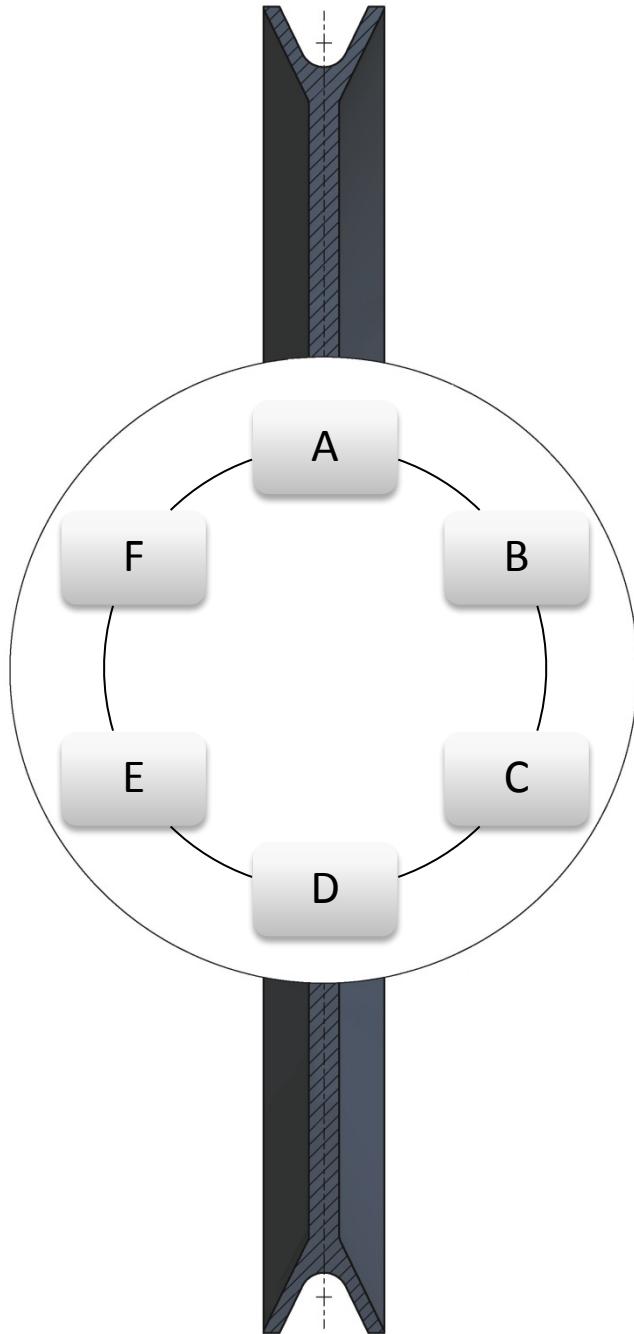

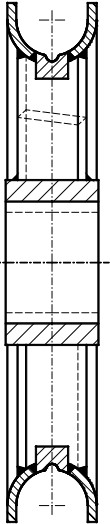

**Special throat sheaves**

These sheaves have a special throat designed for the passage of hoisting cable connected with a linking pear. They are formed by two lateral elements welded to a central machined ring for cable passage. Based on requirement it can be manufactured with similar spokes such as model B or with convex pulleys such as model C.

**Advantages and features**

The sheaves are made with different diameters according to DIN, FEM or on customers' requirements. Laminated sheaves are ideal to replace cast iron sheaves, which represent disadvantages such as frequent control, maintenance, etc. They have no pores, contamination, cavity, non-uniformity. All sheaves are produced in a complete finished state and therefore can be used immediately. There is a considerable reduction of weight under equal conditions and depending upon the size, a 30% decrease in weight compared with a similar cast sheave can be achieved. There is a low inertia torque and high reduction slippage between sheave and cable, thus reducing sheave throat wear. The use of welded sheaves therefore offers high economic advantages.

The ring forming the throat is laminated and cold formed. The hardness detailed in figure 1 below is achieved by this method, using S355J2G3 material. If a greater hardness of the throat is desired, then they can be hardened. We can thus achieve the values according to image 2.

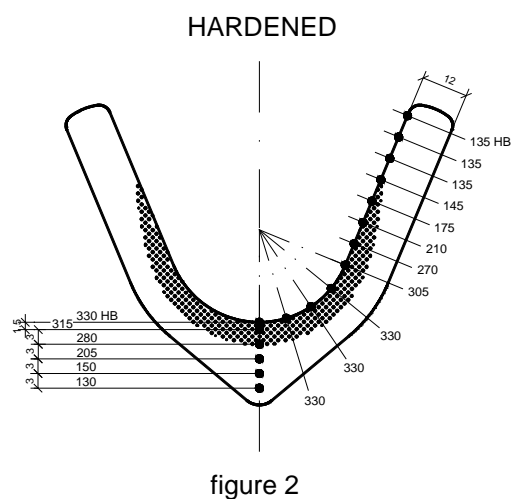
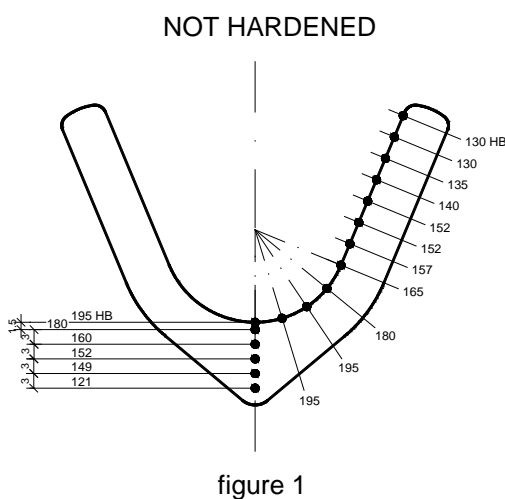

Hardeness (Brinell-HB)

**Amount of sheaves** \_\_\_\_\_

**Bottom of groove diameter** (nominal diameter d2) \_\_\_\_\_ mm

**Overall diameter d3** (if departing from table 1) \_\_\_\_\_ mm

**Rope diameter d1** \_\_\_\_\_ mm

**Groove radius R** \_\_\_\_\_ mm

**Shaft diameter** \_\_\_\_\_ mm

**Bearing** (A - F or extra) \_\_\_\_\_

**Load** (max. rope tensile force) \_\_\_\_\_ kN

**Max. installation space** \_\_\_\_\_ mm

**Wrap angle** (if < 180°) \_\_\_\_\_ °

**Rope fleet angle** (if > 4°) \_\_\_\_\_ °

**For hoisting application**

Stress group (B1 - B6) B \_\_\_\_\_

labyrinth seal

Bearing E + F

shaft seal

**Site of operation** (indoor crane, foundry, maritime, etc.)

.....

.....

.....

.....